



Model AB8600S
Model AP8600S



Metal Man Work Gear Co.
1750 Prospect Ct #106
Appleton, WI 54914
888-762-4045
www.metalmangear.com
email: support@metalmangear.com
MADE IN CHINA

***Auto Darkening
Welding Helmet***



Professional Quality Welding Helmet

WARNING
Read & Understand All Instructions Before Using

Auto-Darkening Welding Helmets are designed to protect the eye and face from sparks, spatter, and harmful radiation under normal welding conditions. auto-darkening filter automatically changes from a light state to a dark state when an arc is struck, and it returns to the light state when welding stops.

Auto-Darkening Welding Helmets comes ready for use. The only thing you need to do before your welding is to adjust the position of the headband and select the correct shade number for your application.

WARNING

- This Auto-Darkening Welding Helmet is NOT suitable for laser welding & Oxyacetylene welding / cutting processes.
 - Never place this Helmet and Auto-darkening filter on a hot surface.
 - Never open or tamper with the Auto-Darkening Filter.
 - This Auto-darkening welding helmet will not protect against severe impact hazards, including grinding disks. Never use for grinding.
 - This helmet will not protect against explosive devices or corrosive liquids.
 - Don't make any modifications to either the filter or helmet, unless specified in this manual. Don't use replacement parts other than those specified in this manual. Unauthorized modifications and replacement parts will void the warranty and expose the operator to the risk of personal injury.
 - Should this helmet not darken upon striking an arc, stop welding immediately and contact your supervisor or your dealer.
Don't immerse the filter in water.
 - Don't use any solvents on filters' screen or helmet components.
 - Use only at temperatures : -10° C ~ + 55° C (14° F ~ 131° F).
 - Storing temperature : -20° C ~ + 70° C (- 4° F ~ 158° F).
 - Protect filter from contacting with liquid and dirt.
 - Clean filters' surfaces regularly; do not use strong cleaning solutions.
- Always keep sensors and solar cells clean using a clean lint-free tissue/cloth.
- Regularly replace the cracked/scratched/pitted front cover lens.
 - The materials which may come into contact with the wearers skin, can cause allergic reactions in some circumstances.

WARNING
Severe personal injury could occur if the user fails to follow the above mentioned warnings, and/or fails to follow the operating instructions.

COMMON PROBLEMS AND REMEDIES

- **Irregular Darkening Dim ming**
Headband has been set unevenly and there is an uneven distance from the eyes to the filter's lens (Reset headband to reduce the difference to filter).
- **Auto-Darkening Filter Does Not Darken Or Flickers**
 - ① Front cover lens is dirty or damaged (change lens cover)
 - ② Sensors are dirty (clean the sensors' surface)
 - ③ Welding current is too low (turns the switch to the "slow" position).
- **Slow response**
Operating temperature is too low (do not use at temperatures below -10°C or 14 ° F).
- **Poor Vision**
 - ① Front /inside cover lens and/or filter lens are dirty (change lens)
 - ② There is insufficient ambient light
 - ③ Shade number is incorrectly set (reset the shade number)
- **Welding Helmet Slips**
Headband is not adjusted properly (readjust headband)

WARNING

User must stop using the auto-darkening welding helmet immediately if the above-mentioned problems cannot be corrected. Contact the dealer.

INSTRUCTIONS FOR USE
WARNING! Before using the helmet for welding ensure you have read and understood the safety instructions

- The helmet comes ready assembled but before it can be used it must be adjusted to fit the user properly and set up for delay time, sensitivity and shade level
- **ADJUSTING THE FIT OF THE HELMET**
The overall circumference of the headband can be made larger or smaller by pushing in and rotating the knob on the back of the headband. (See adjustment "Y" in fig.1). This can be done while wearing the helmet and allows just the right tension to be set to keep the helmet firmly on the head without it being too tight.
- If the headband is riding too high or too low on your head adjust the strap which passes over the top of your head. To do this release the end of the band by pushing the locking pin out of the hole in the band. Slide the two portions of the band to a greater or lesser width as required and push the locking pin through the nearest hole (See adjustment "W" in fig.1)
- Test the fit of the headband by lifting up and closing down the helmet a few times while wearing it. If the headband moves while tilting re-adjust it until it is stable.

● ADJUSTING DISTANCE BETWEEN HELMET & FACE

Step 1: Loosen the nut (See "T" in fig.1) to adjust the distance between the helmet and your face in the down position.

Step 2: Loosen the nut on either side of the helmet and slide it nearer to or further from your face. (See adjustment "Z" in fig.1) It is important that your eyes are each the same distance from the lens otherwise the darkening effect may appear uneven.

Step 3: Re-tighten the nut when adjustment is complete.



● ADJUSTING VIEW ANGLE POSITION

Please see fig.2



fig.2

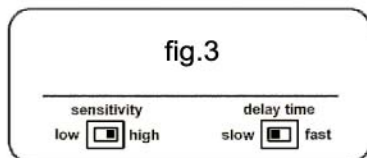

● SELECTING SHADE LEVEL

Select the shade level you require according to the welding process you will use by referring to the "Shade Guide Table" on page 5 for settings. Turn the shade control knob on the side of the helmet to the shade number required.

● SELECTING DELAY TIME

When welding ceases the viewing window automatically changes from dark back to light but with a pre-set delay to compensate for any bright afterglow on the workpiece. The delay time/response can be set to "fast" (0.25secs to 0.3) or "slow" (0.65secs to 0.8) as you require using the microswitch on the back of the shade cartridge. (See fig.3)

● SENSITIVITY

The sensitivity can be set to "high" or "low" using the micro-switch on the back of the shade cartridge. The "high" setting is the normal set-ting for everyday use. Where the operation of the mask is disturbed by ex-cess ambient light or another welding machine close by, use the "low" setting.(See fig.3)

● You are now ready to use the helmet, The shading may be adjusted during use by re-setting potentiometer control.

MAINTENANCE

● REPLACE THE FRONT COVER LENS. Replace the front cover lens if it is damaged (cracked, scratched, dirty or pitted) Place your finger or thumb into the recess at the bottom edge of the window and flex the window upwards until it releases from one edge. (See fig.4)

REPLACE THE INNER COVER LENS if it is damaged (cracked, scratched, dirty or pitted).

● CHANGING THE SHADE CARTRIDGE.(See figs.5a & 5b)

● INSTALLING NEW CARTRIDGE. Take the new shade cartridge and pass the potentiometer cable under the wire loop before dropping the cartridge into its retaining frame inside the helmet. Press down the wire loop clip and ensure that the front edge of the loop is properly retained under the retaining lugs as shown in fig.5b.

● Magnifying lens is held in place by wire clip.

● Fasten the potentiometer to the inside of the helmet with the shaft protruding through the hole. Push the shade control knob onto the shaft

● CLEANING. Clean helmet by wiping with a soft cloth. Clean cartridge surfaces regularly. Do not use strong cleaning solutions. Clean sensors and solar cells with methylated spirit and a clean cloth and wipe dry with a lint-free cloth.

TECHNICAL SPECIFICATIONS

Viewing Area :	98 x 44 mm (3.86"x1.73")
Cartridge Size:	110 x 90 x 9 mm (4.33"x3.54"x0.35")
UV/IR Protection :	Up to Shade DIN16 at all times
Arc sensor:	2
Light State:	Shade DIN 3.5
Variable Shade:	DIN 9 to 13
Shade Control:	External knob - full adjustment
Power On/Off:	Fully Automatic
Sensitivity Control:	Adjustable
Switching Time:	1/10,000 sec. from Light to Dark
Delay Control:	0.25 ~ 0.30s <fast> 0.65 ~ 0.80s <slow>
Power Supply:	Solar cell. No battery change required
Operating Temperature:	-10°C ~ +55°C (-14°F ~ 131°F)
Storing Temperature:	-20°C ~ +70°C (-4°F ~ 158°F)
Helmet Material:	High Impact Resistance Nylon
Total Weight:	1.09Lbs
Application range:	MIG; MAG/CO2; SMAW; Air carbon cutting; PLASMA arc welding/cutting; TIG Rating, 10 amps
Compliance:	ANSI Z87.1-2003 / CSA Z94.3

PARTS LIST & ASSEMBLY

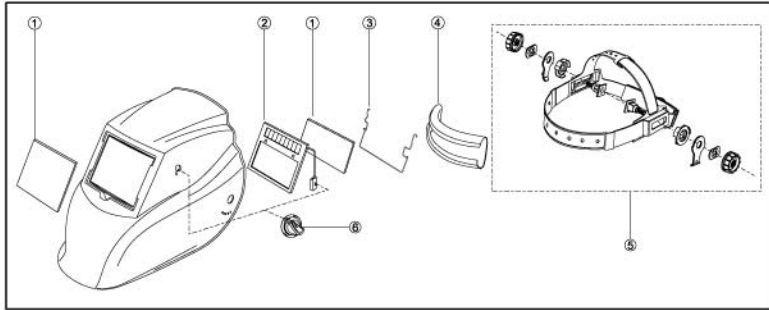

Reference Number	Description	Part No.
1	Lens kit (4 front / 2 inside Lens Covers) (2 front / 1 inside Lens Covers)	MLK8186 MLK8186-2/1
2	Replacement lens	MRL86
3	Retaining wire	MRW8
4	Sweat band	MSB8
5	Headgear	MHG8
6	Shade control knob	MSC86

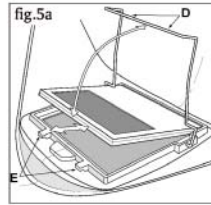
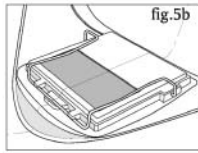
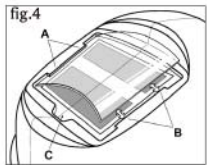

SHADE GUIDE TABLE (No.1)

Welding Process	ARC CURRENT (Amperes)																							
	0.5	2.5	10	20	40	80	125	175	225	275	350	450	1	5	15	30	60	100	150	200	250	300	400	500
SMAW					9	10	11		12		13	14												
MIG (heavy)							10	11	12	13	14													
MIG (light)							10	11	12	13	14	15												
TIG, GTAW			9	10	11	12		13		14														
MAG/CO ₂					10	11	12		13		14	15												
SAW							10	11	12	13	14	15												
PAC								11	12		13													
PAW			8	9	10	11	12		13		14	15												

NOTE:
 SMAW – Shielded Metal Arc Welding MIG (Heavy) – MIG on Heavy Metals
 TIG, GTAW – Gas Tungsten Arc Welding PAW – Plasma Arc Welding
 PAC – Plasma Arc Cutting MAG/CO₂ – Metal Active Gas
 SAW – Shielded Semi-Automatic Arc Welding
 MIG (Light) – MIG on Light Alloys